

HIGH SPIN INDUSTRIAL WASHER EXTRACTORS

FS
RANGE

FS 800 **FS 100** **FS 1200**

80KG 100KG 120KG
177LB 220LB 265LB



FEATURES

- Freestanding, high spin
- Stainless steel cabinet (AISI 304)
- Stainless steel drum and tub
- Xcontrol Plus - Fully programmable microprocessor
- Extra large door opening (FS800, FS1000 Ø 530 mm, FS1200 Ø 650 mm)
- Two large drain valves (Ø 103 mm)
- Easy access to all parts
- Standard liquid soap connections
- Frequency controlled motor
- PowerWash® perforated lifting ribs: more mechanical action, lower water consumption
- Air operated water inlet
- SuperEco washing programmes - significantly reduces water and electricity consumption
- Patented soap dispenser with 5 removable compartments

OPTIONS

- Liquid soap pumps
- Trace-Tech® traceability software and networking system
- Forward and backward tilting is available. Tilting of the machine is done by external platform



ROBUST DESIGN



LARGE DOOR
OPENING



EASY
OPERATION

TRACE-TECH

POWERWASH

XCONTROL+

supereco
washing programmes

GET AHEAD IN LAUNDRY+

TYPE		FS800	FS1000	FS1200
CAPACITY				
Drum volume	l	807	1003	1180
Capacity	kg/lb	80/180	100/230	120/275
Drum diameter	mm	Ø 1110	Ø 1200	Ø 1300
MOTOR				
Frequency controlled		standard	standard	standard
DRUM SPEED				
Wash speed	rpm	36	33	32
Spin speed	rpm	750	720	695
G-Factor		350	350	350
PROGRAMMER				
Xcontrol Plus microprocessor		standard	standard	standard
CABINET				
Stainless steel AISI 304		standard	standard	standard
DRUM				
Stainless steel AISI 304		standard	standard	standard
HEATING				
Electrical	kW	67,5	-	-
Steam high pressure	bar	3-8	3-8	3-8
	psi	44-116	44-116	44-116
CONNECTION				
Electrical		3x380-480V 50/60Hz 3x208-240V 50/60Hz	3x380-480V 50/60Hz 3x208-240V 50/60Hz	3x380-480V 50/60Hz 3x208-240V 50/60Hz
	kW	11,25	15,25	18,75
Water inlet	inch	3x1 1/2"	3x1 1/2"	3x1 1/2"
Steam inlet	inch	1"	1"	1"
Compressed air inlet	mm	Ø 8	Ø 8	Ø 8
Drain	mm	2x103 2x4"	2x103 2x4"	2x103 2x4"
DIMENSIONS				
H×W×D	mm	1985×1495×1940	2060×1790×2005	2085×1855×2085
Net weight	kg	2640	3170	3480
TRANSPORT DATA				
Volume (packed)	m ³	7,25	9,29	10,16
Packed H×W×D	mm	2200x1690x1950	2345x1865x2125	2340x2000x2170
Gross weight	kg	2830	3410	3710

- = Not available

Standard = Standard execution, The data concerning dimensions of machines include all extended parts

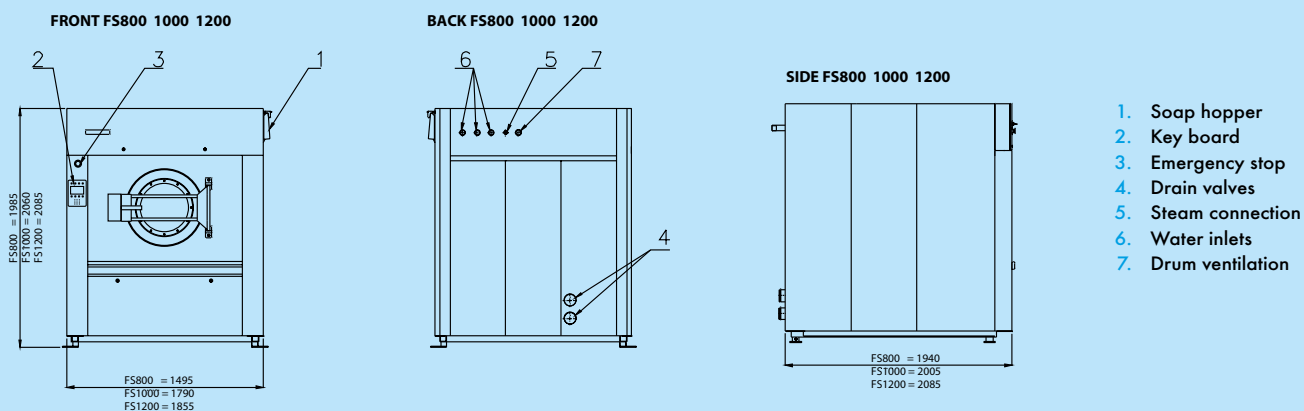

The company preserves the right to change the machines and the specification in this leaflet at any time, without prior notice. Details and photographs are only for information and never binding.

www.primuslaundry.com

Primus by Alliance Laundry Systems



12-2017