

INDUSTRIAL CYLINDER HEATED DRYING IRONER

I
RANGE

I 80	IR 80	IF 80	IFF 80
800MM	800MM	800MM	800MM



FEATURES

- Large surface contact with linen
- Finger protection and emergency button for more safety
- Automatic cooldown
- MCX- Easy to operate microprocessor
- Overdimensioned fan for flexible installation
- Indication of ironing speed and temperature
- Reverse mode possible
- Frequency controlled motor
- Space saving installation against the wall is possible: front return
- Electric, gas or steam heating
- OCS - Overheating check system
- IR80 - Frontal and rear output
- IF80 - module R with length folding
- IFF80 - ironer with feeding and length folding

CROSSFOLDER



STACKER



OPTIONS

- Stop pedal
- Vacuum table
- CS - cross folder and stacker



ROBUST DESIGN



HIGH OUTPUT



MODULAR SYSTEM

TYPE		I80			IR80			IF80			IFF80		
		E	G	S	E	G	S	E	G	S	E	G	S
ROLLER DIAMETER	mm	800			800			800			800		
USEFUL ROLLER LENGTH	mm	3186			3186			3186			3186		
POWER													
Heating	kW (E,G) kg/h (S)	75	103*	190	75	103*	190	75	103*	190	75	103*	190
ROLLER MOTOR	kW	0,9			1,15			1,25			2		
FAN MOTOR	kW (50/60Hz)	2×0,55/0,75			2×0,55/0,75			2×0,55/0,75			2×0,55/0,75		
IRONING CAPACITY**	kg	195			195			195			195		
ROLLER SPEED	m/min.	3-15			3-15			3-15 (3-8 with length folding)			3-15 (3-8 with length folding)		
FAN CAPACITY	m ³ /h	2×1300			2×1300			2×1300			2×1300		
ELECTRIC CONNECTION		380-415V 3AC+N 50/60 Hz 208-240V 3AC 50/60 Hz 380-415V 3AC-N 50/60 Hz 440-480V 3AC 60 Hz											
DIMENSIONS H×W×D	mm	1985×4260×1915			1985×4260×1915			1985×4260×1915			1985×4260×1915		
Weight netto	kg	2610	2480	2900	2860	2730	3150	2970	2840	3260	3170	3040	3460
PACKING DIMENSIONS													
H×W×D	mm	2080×4380×2080			2080×4380×2080			2080×4380×2080			2080×4380×2080		
Weight brutto	kg	2870	2740	3160	3120	2990	3410	3230	3100	3520	3430	3300	3720

* G20, 20 mbar

** According to ISO 9398-1

Standard version

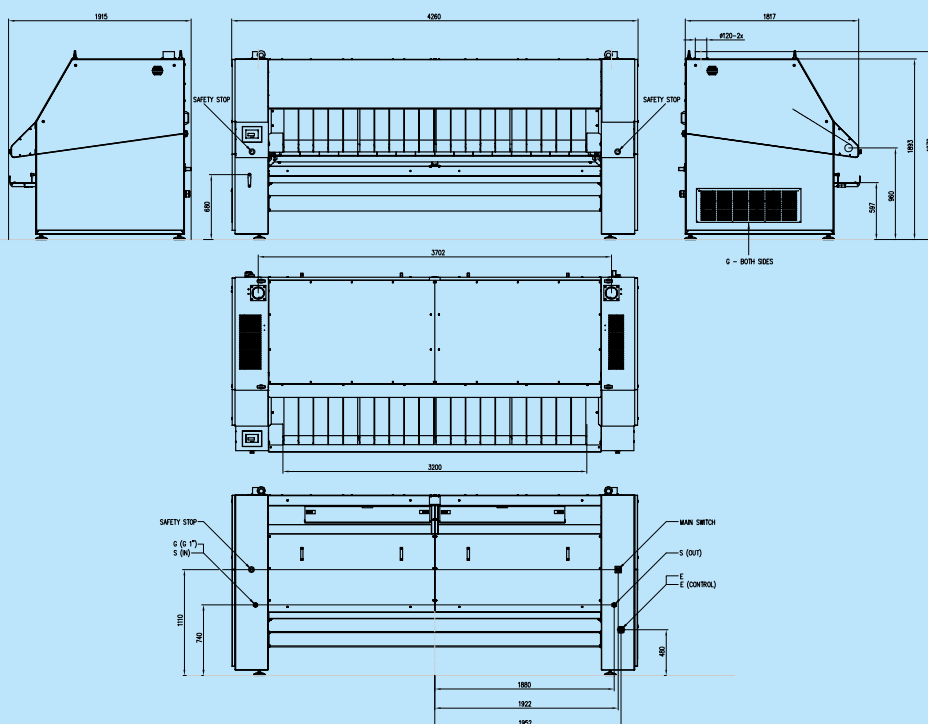

The company preserves the right to change the machines and the specification in this leaflet at any time, without prior notice. Details and photographs are only for information and never binding.

www.primuslaundry.com

Primus by Alliance Laundry Systems



12-2017